

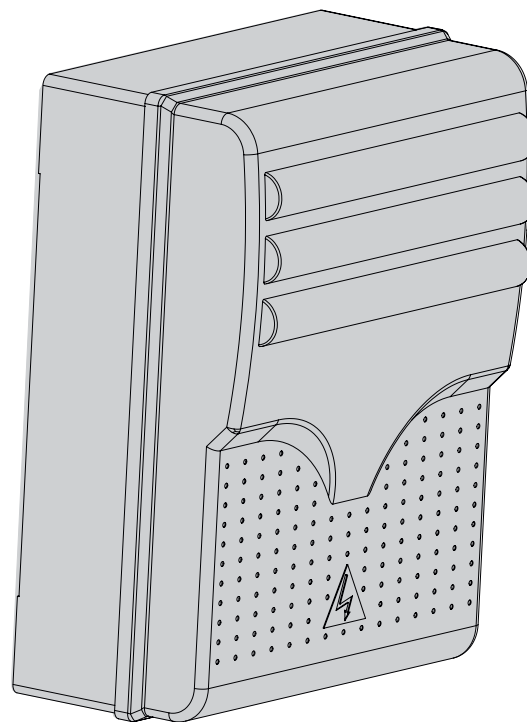

Control panel for CBXET

# ZT5-ZT5C

CE





INSTALLATION MANUAL

**“IMPORTANT INSTRUCTIONS FOR SAFE INSTALLATION”**

**CAUTION: INCORRECT INSTALLATION CAN CAUSE SERIOUS DAMAGE. PERFORM ALL THE INSTALLATION INSTRUCTIONS THIS MANUAL HAS BEEN WRITTEN SPECIFICALLY FOR A PROFESSIONAL INSTALLER OR OTHER SPECIFICALLY TRAINED PERSON.**

## 1 Legend

-  This symbol indicates sections to be read with particular care.
-  This symbol indicates sections concerning safety.
-  This symbol indicates notes to communicate to users.

## 2 Destination and use Precautions applications

### 2.1 Destination

The ZT5-ZT5C electrical panel (ZT5C version with built-in command keys and safety lock) were designed to control CBXET automation units in the movement of sectional, sliding and swing gates.

### 2.2 Precautions applications

- Comply with the distances and diameters of the cables shown in the table in Chap. 5.4
- Locate the panel in areas protected from accidental blows.
- For the ZT5C version, position the panel at a height of 1.5 m from the ground

## 3 Standards followed

The following standards were complied with for this product: EN 12978, UNI EN 954-1, CEI EN 60335-1, UNI EN 12453.

## 4 Description

### 4.1 Three-phase electric panel

Ratiomotor electrical panel with three-phase 230/400V power; 50÷60 Hz frequency.

Designed and built entirely by CAME Cancelli Automatici S.p.A. Case with air recycling inlet. 2-year guarantee unless tampered with.

### 4.2 Technical information

Electrical panel

Power supply: 230V / 400V - 50÷60 Hz.

Maximum power allowed: 780 W

Absorption at rest: 55 mA

Maximum power for 24V accessories: 20 W

Maximum power for 230V accessories: 200 W

Degree of protection: IP54

Insulation type: II



Material: ABS

Working temperature:



### 4.3 Main components

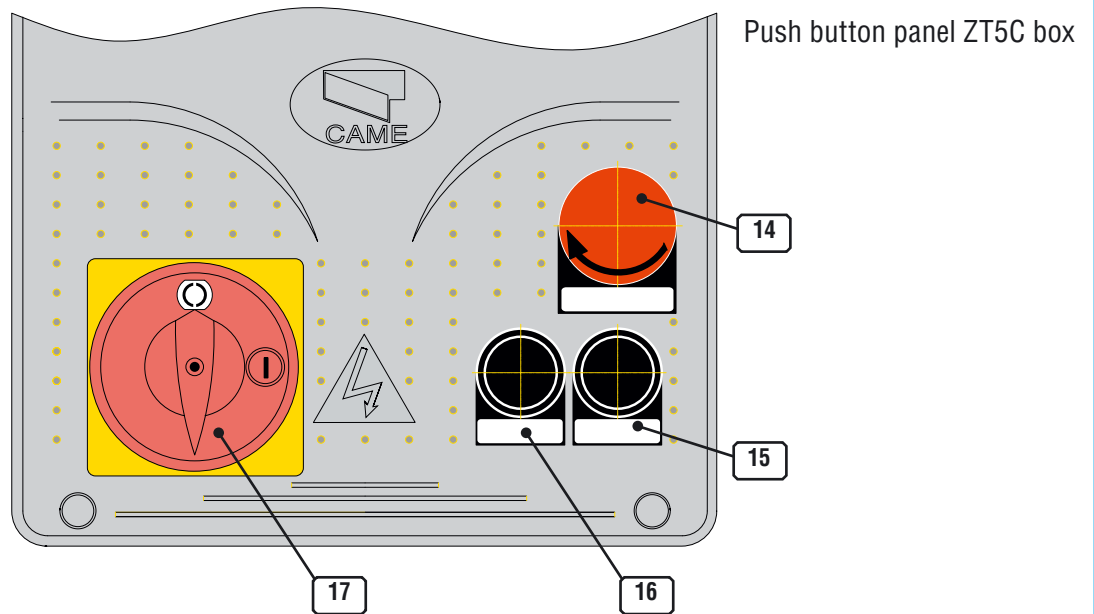
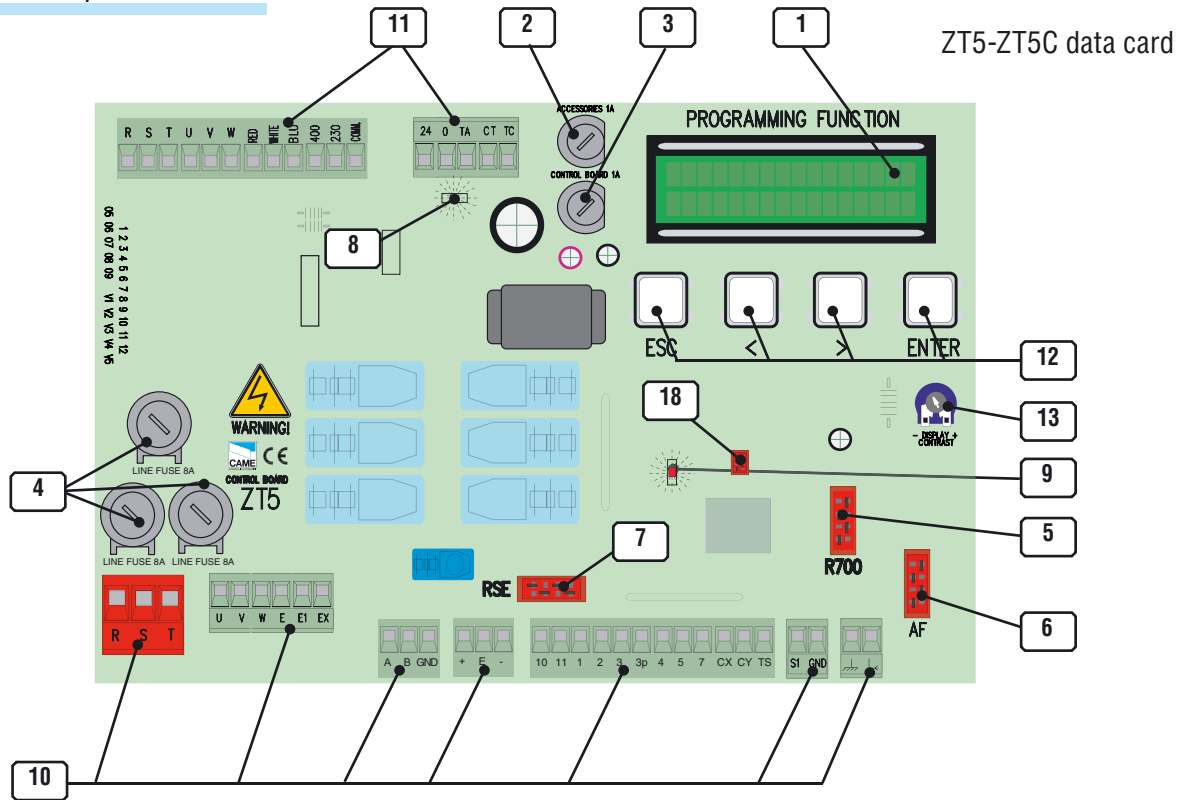

- 1-Display
- 2- 1A fuse for accessories
- 3- 1A fuse for control unit
- 4- 8A line fuses
- 5- R700 board connector
- 6- AF board connector
- 7- RSE board connector for signal decoding for PC interfacing (for multiple control of up to 16 units)
- 8- Power LED indicator
- 9- Activated safety contacts LED indicator
- 10- Connection terminal board
- 11- Transformer connection terminal board
- 12- Programming keys
- 13- Display screen contrast adjustment trimmer
- 14- STOP key
- 15- CLOSE key
- 16- OPEN key
- 17- Safety lock
- 18- Memory roll (system and user data backup device) board connector

All the data and information contained herein is considered subject to change at any time and at our discretion.

## 5 Installation

### 5.1 Preliminary checks



Before proceeding with the installation, it is necessary to:

- Check that the control panel is installed in an area protected from bumps and that the anchorage surface is solid, and that it is secured with suitable elements (screws, inserts, etc).
- Provide for suitable omnipolar disconnection device with more than 3 mm between contacts to section power supply.
- Ⓢ Connections inside the case made for protection circuit continuity are allowed as long as they include additional insulation with respect to other internal drive parts.
- Install suitable tubes and ducts for electric cable passage to guarantee protection against mechanical damage.

### 5.2 Equipment and materials

Make sure all the necessary tools and materials are available to carry out the installation with the maximum safety, in compliance with regulations in force. Here are some examples.

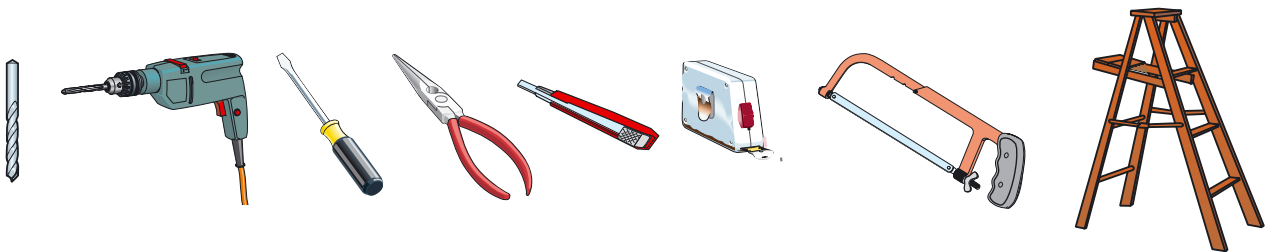

### 5.3 Dimensions, axle bases and fastening holes

Max. 6 mm Phillips round head screws are recommended.

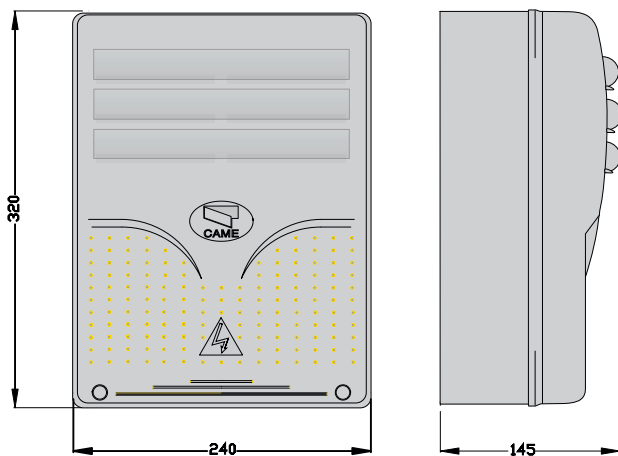

Dimensions of ZT5 case

Dimensions of ZT5 C case

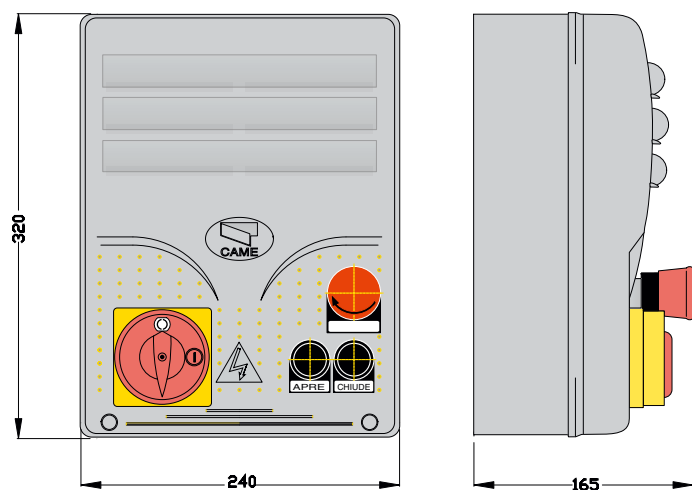

All the data and information contained herein is considered subject to change at any time and at our discretion.

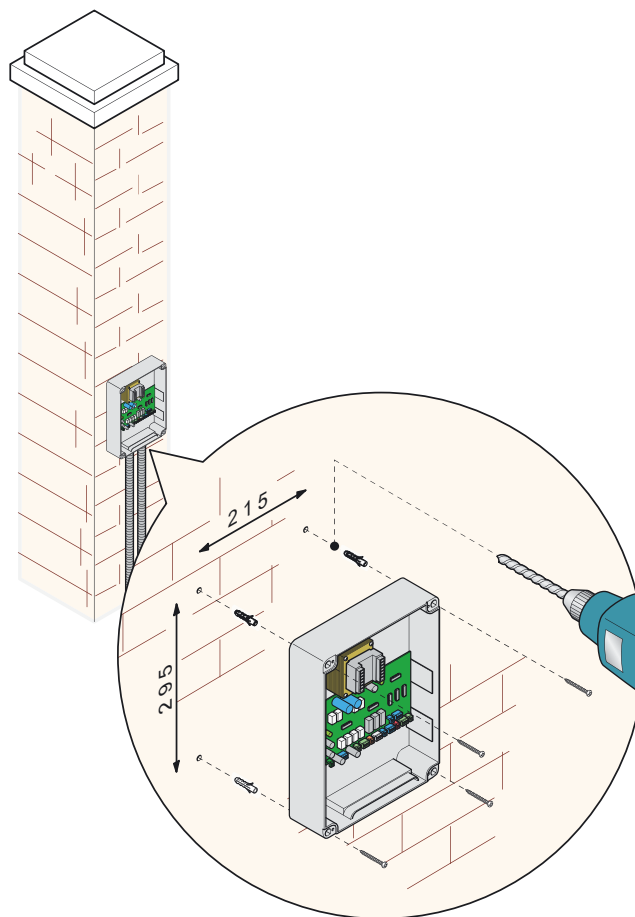
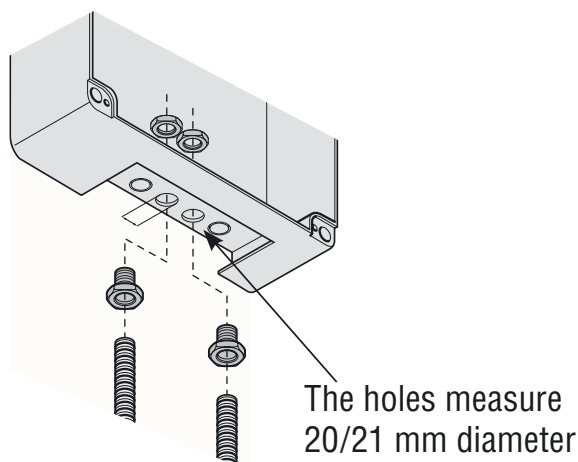

### 5.4 Minimum thickness and type of cables

Connections	Type of cable	Length of cable 1<10 M	Length of cable 10<20 M	Length of cable 20<30 M
230/400V 3F power supply line	FROR CEI 20-22 CEI EN 50267-2-1	4G 1,5mm <sup>2</sup>	4G 2,5mm <sup>2</sup>	4G 4mm <sup>2</sup>
230V 2F power supply line		3G 1,5mm <sup>2</sup>	3G 2,5mm <sup>2</sup>	3G 4mm <sup>2</sup>
230/400V 2F/3F motors		4G 1mm <sup>2</sup>	4G 1,5mm <sup>2</sup>	4G 2,5mm <sup>2</sup>
24V motors		2 x 1mm <sup>2</sup>	2 x 1,5mm <sup>2</sup>	2 x 2,5mm <sup>2</sup>
230V flashing lamp		2 x 0,5mm <sup>2</sup>	2 x 1mm <sup>2</sup>	2 x 1,5mm <sup>2</sup>
24V flashing lamp		2 x 0,5mm <sup>2</sup>	2 x 1mm <sup>2</sup>	2 x 1,5mm <sup>2</sup>
230V courtesy / cycle light		3G 0,5mm <sup>2</sup>	3G 1mm <sup>2</sup>	3G 1,5mm <sup>2</sup>
24V power supply accessory		2 x 0,5mm <sup>2</sup>	2 x 0,5mm <sup>2</sup>	2 x 1mm <sup>2</sup>
24V pilot light		2 x 0,5mm <sup>2</sup>	2 x 0,5mm <sup>2</sup>	2 x 1mm <sup>2</sup>
24V "in motion" output		2 x 0,5mm <sup>2</sup>	2 x 0,5mm <sup>2</sup>	2 x 1mm <sup>2</sup>
Safety contacts		2 x 0,5mm <sup>2</sup>	2 x 0,5mm <sup>2</sup>	2 x 0,5mm <sup>2</sup>
N.O./N.C. control button		2 x 0,5mm <sup>2</sup>	2 x 0,5mm <sup>2</sup>	2 x 0,5mm <sup>2</sup>
End stop		3 x 0,5mm <sup>2</sup>	3 x 1mm <sup>2</sup>	3 x 1,5mm <sup>2</sup>
Command 2nd combined motor		1 x 0,5mm <sup>2</sup>	1 x 0,5mm <sup>2</sup>	1 x 1mm <sup>2</sup>
Antenna connection (max 50M)		RG58		
Encoder connection (max 30M)		2402C 22AWG shielded cable		

N.B.: An evaluation of the size of the cables with lengths other than the data in the table must be made based on the effective absorption of the connected devices, according to the instructions indicated by the CEI EN 60204-1 standards. For connections that require several loads on the same line (sequential), the size given on the table must be re-evaluated based on actual absorption and distances.

## 5.5 Electrical connections



230/400V A.C. power supply; three phase (ZT5)

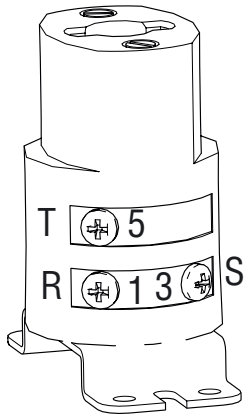

Connections on R, T, S 230/400V A.C. power supply; three-phase (ZT5C)



230V/400V 50-60 H three-phase motor ,Maximum power: 780W



230V A.C. 25W max. (in motion) output for flashing lamp

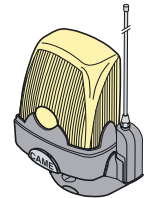

230V max. 60W courtesy or cycle light (select from software)



Serial communication for PC connection, use mod. RS235 shielded bipolar cable with software (optional)

PC 40 or PC30

RS232 cable

Personal Computer

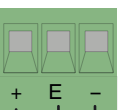

Connection for encoder (for connection between automation and electrical panel, use shielded 2402C 22AWG cable)

All the data and information contained herein is considered subject to change at any time and at our discretion.

## 5.5 Electrical connections

All the data and information contained herein is considered subject to change at any time and at our discretion.

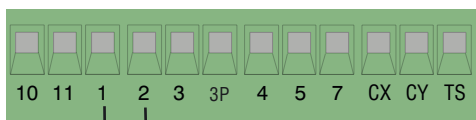

(1-2) STOP Button N.C.



(2-3P) Partial opening N.O. button

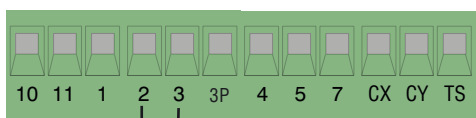

(2-3) Total opening N.O. button



(2-4) Closure N.O. button



(2-7) Open-close contact (Step step)  
or Open-stop-close-stop (Sequential) N.O.



(10-5) Open pilot light 24V 3W

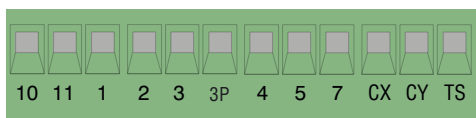

10-11 output 24V A.C power supply accessories, max 20 W

### Antenna connection

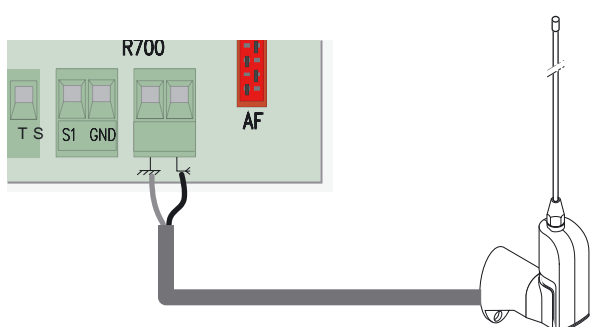

## 5.5 Electrical connections

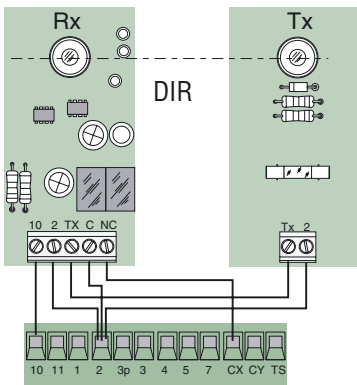

(2-CX) photoelectric cell DOC and DIR connection

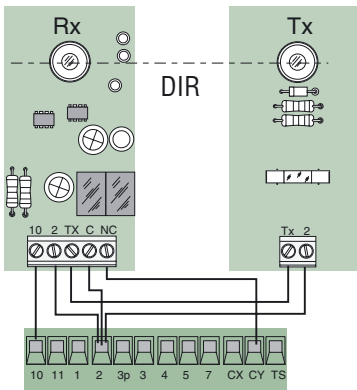
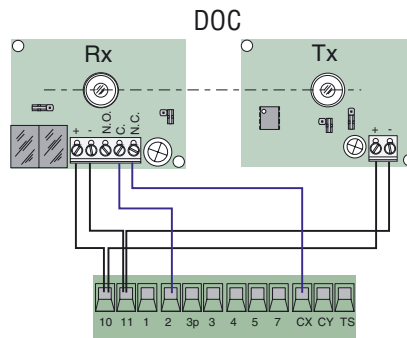

(2-CY) photoelectric cell DOC and DIR connection

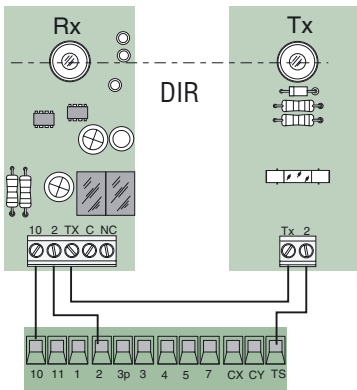
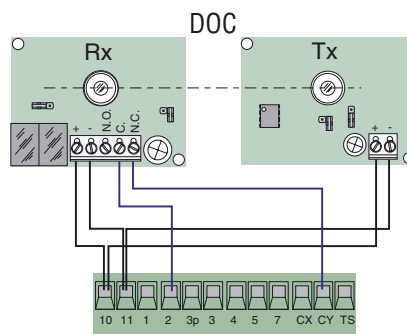

Photoelectric cell DOC and DIR functional test

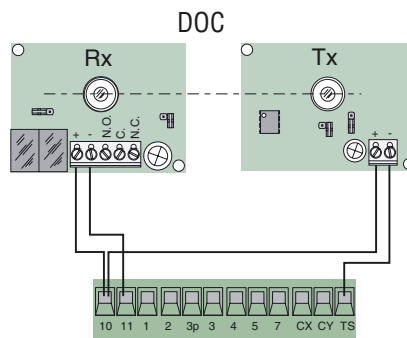

(S1-GND) connection of sensors TSP00 (transponder) LT001 (swipe)

N.B. for the sensors to recognize the card, connect them with the special decoder card (R700).

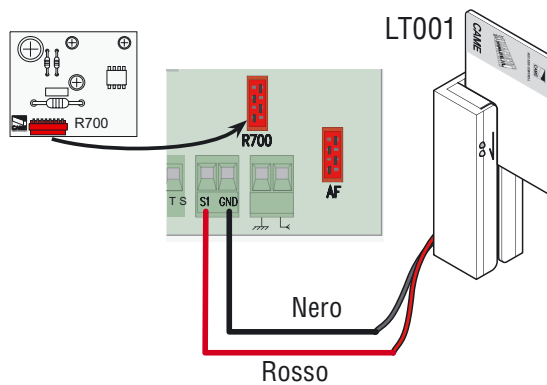
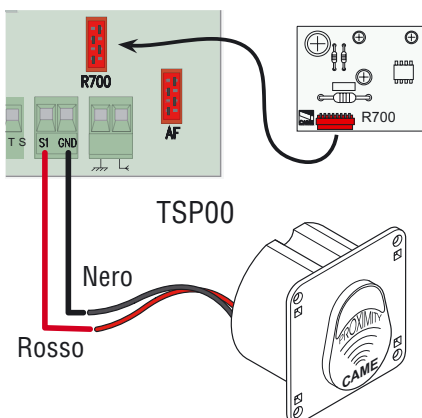

All the data and information contained herein is considered subject to change at any time and at our discretion.



## 6 Planning

### 6.1 Description display controls

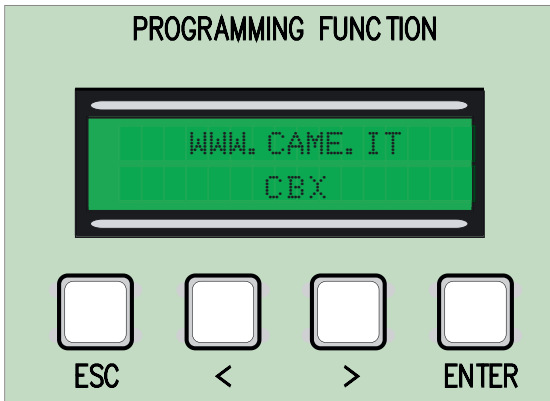

The ENTER key serves to :  
 - enter the menu  
 - confirm and memorize the set value



The ESC key serves to :  
 - exit the menu  
 - cancel the modifications

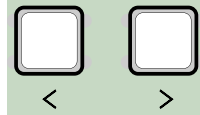

The < > keys serve to:  
 - move from one menu item to another  
 - increase or decrease a value

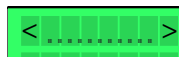

The <.....> indicators on the display serve to:  
 - indicate the item currently selected

All the data and information contained herein is considered subject to change at any time and at our discretion.

### 6.2 Menu browsing



To enter the menu, press and keep the ENTER key depressed for at least one second.

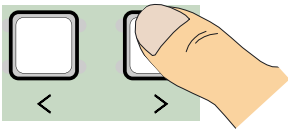

To select the menu item, use the arrows to move to the item desired.

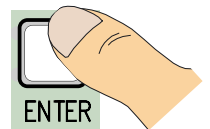
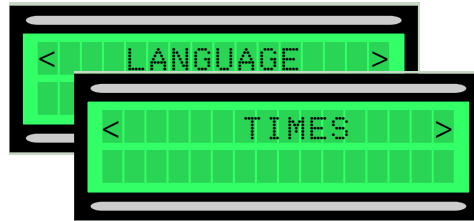

.. then press ENTER

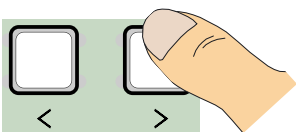

For submenus, use the arrows to move to the item desired.

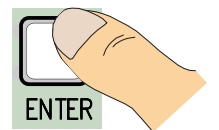

.. then press ENTER



If the <> arrow keys are on the time, it means that it can be modified.

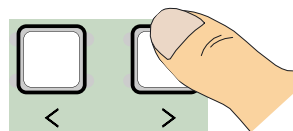

Increase or decrease a value using the arrow keys to reach the value desired...

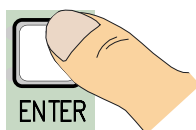

.. Then press the ENTER key to confirm.

To exit the menu, wait 30 seconds or press ESC until the start window appears

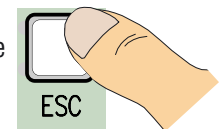

N.B. it is not possible to move around when the menu is active.

# 6.3 Menu structure

ENGLISH

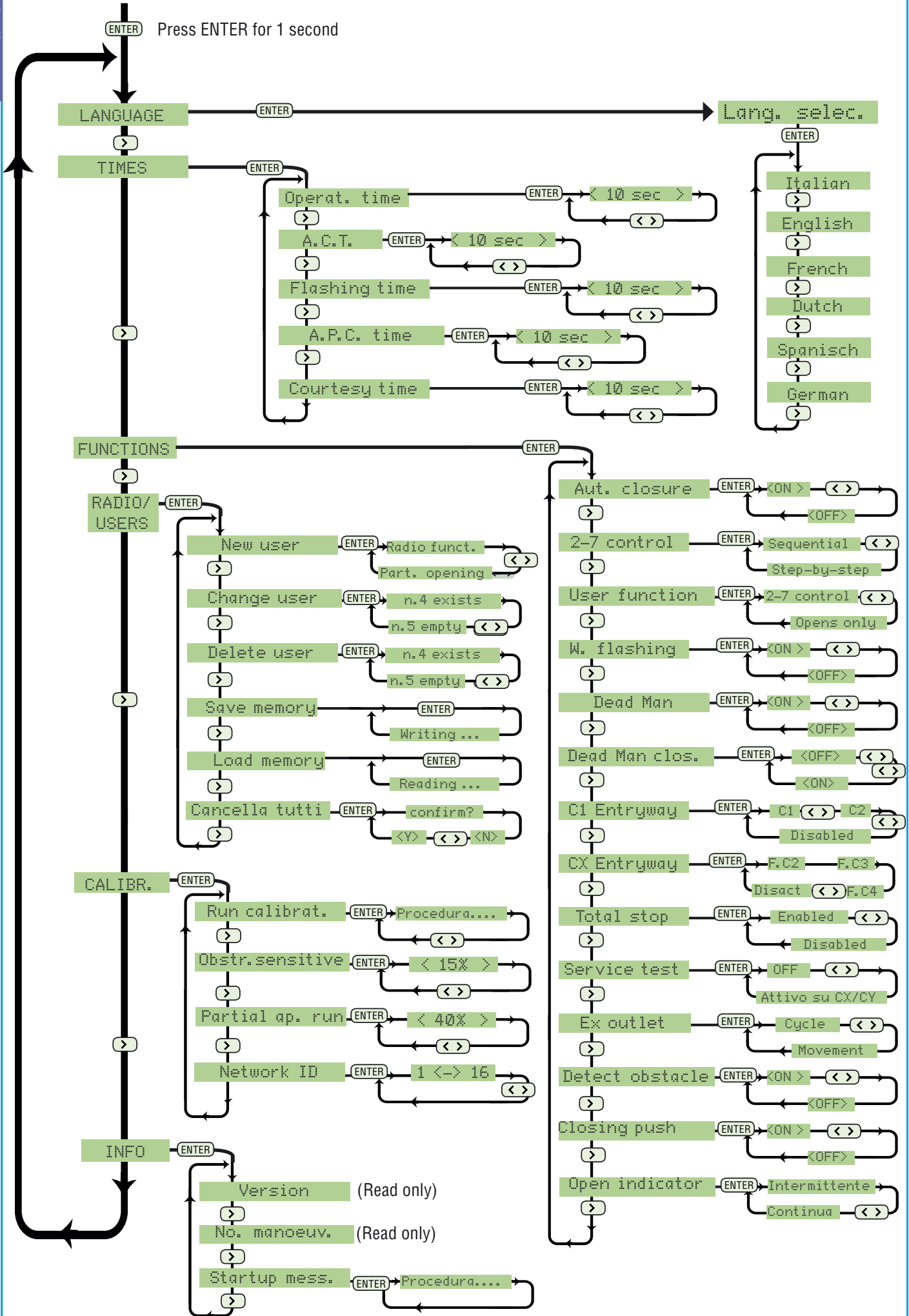

All the data and information contained herein is considered subject to change at any time and at our discretion.

## 6.4 Menu entries

### Language

**Language selection:** This selects the language of the menu from the available languages.



### Time

**Operating time:** motor operating time during a single 10" to 120" opening or closing operation.

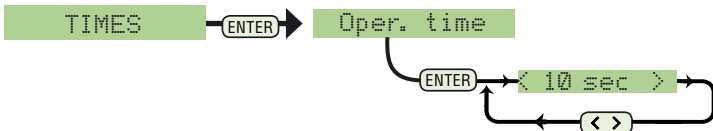

**T.C.A.:** automatic closing time from 1" to 120" after an opening command is carried out.

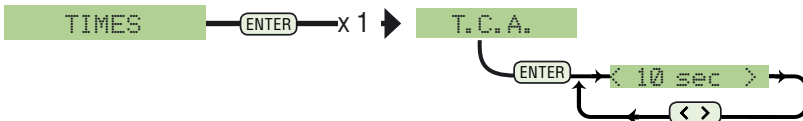

**Pre-flashing time:** pre-flashing duration: 1" to 5".

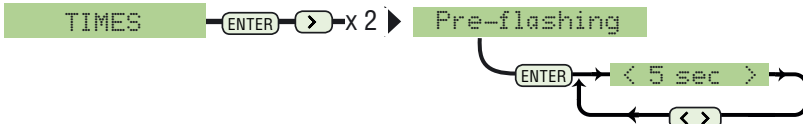

**Pedestrian T.C.A.:** 1" to 120" automatic closing time after the execution of a pedestrian opening operation.

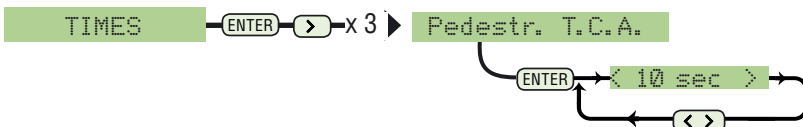

**Courtesy time:** the courtesy light remains on from 1" to 120".

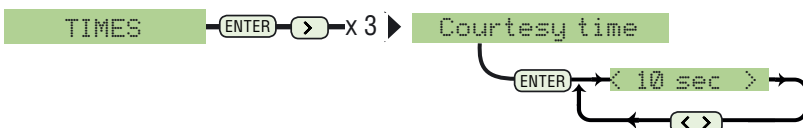

### Functions

**Automatic closure:** enables or disables the automatic closing function.

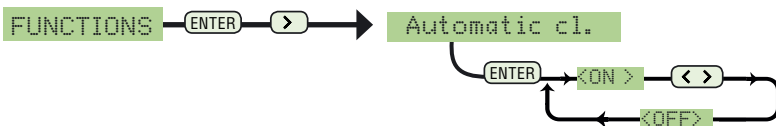

**Command 2-7:** sets the sequential or stepper contact.

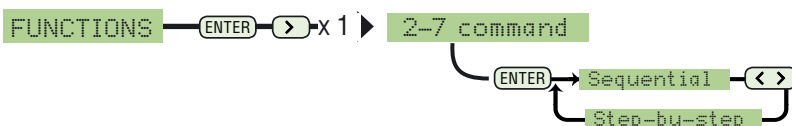

**User function:** sets the user or the opening only command or the function associated with command 2-7

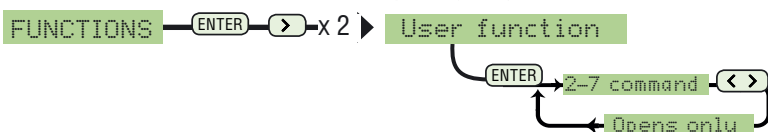

**Pre-flashing:** enables or disables the pre-flashing function.



All the data and information contained herein is considered subject to change at any time and at our discretion.

## 6.4 Menu entries

**Dead Man (maintained action):** enables or disables the function (maintained action).



**Closing Dead Man (maintained closing action):** enables or disables the function (maintained action during closing).



**CY inlet:** N.C. safety contact inlet with the option to associate the following functions  
 C1: Reopening while closing, C2: Reclosing while opening, C3: partial stop, C4: Obstacle wait,  
 C6: Reopening while closing (for safety rib).

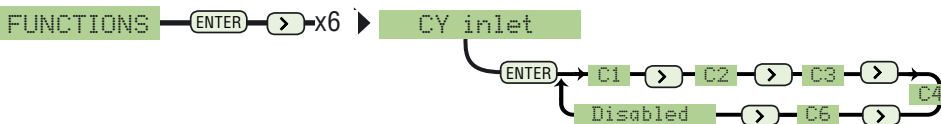

**CX inlet:** N.C. safety contact inlet with the option to associate the following functions  
 C1: Reopening while closing, C2: Reclosing while opening, C3: Partial stop, C4: Obstacle wait,  
 C6: Reopening while closing (for safety rib).

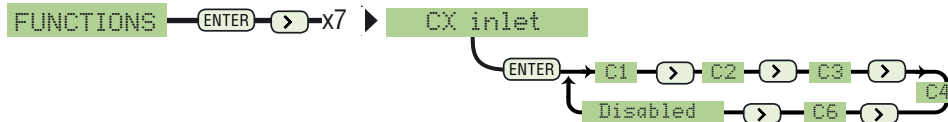

**Total Stop:** enables or disables total stop.



**Service test:** checks the correct functioning of safety devices and selects the inlets they are connected to.

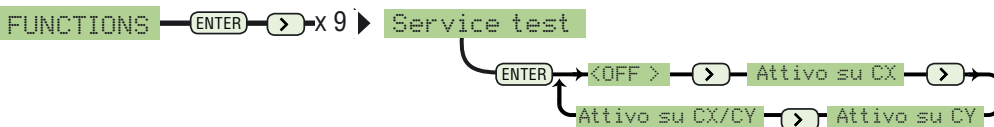

**Lamp output:** output for connection of 230V lamp that may be set in two function modes  
 - Cycle: the flashing lamp is in function until the automatism returns to the closing position.  
 - Movement: the flashing lamp works only while the automatism is moving.



**Reveal obstacle:** prevents movement with the motor shut down until the safety devices detect an obstacle

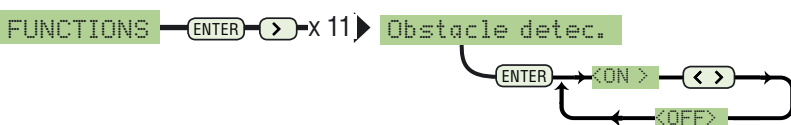

**Closing push:** added push to improve closure. (May be used if the pavement is irregular)



**Open indicator:** enables the movement signalling indicator.

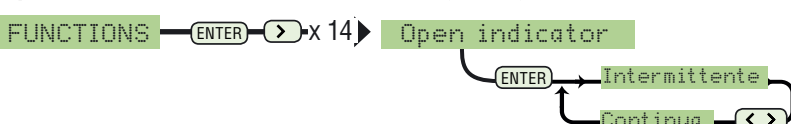

All the data and information contained herein is considered subject to change at any time and at our discretion.

## 6.4 Menu entries

**Radio/User** Shut the power off prior to inserting a coding board to the control panel (see pg. 15).

**New user:** to create new users



**Change user:** to make changes in the functions associated to users.



**Remove user:** to delete users. (see pg. 14)

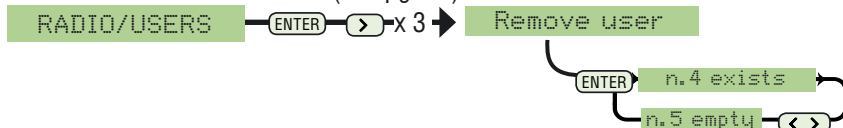

**Save memory:** to save users in the memory roll.

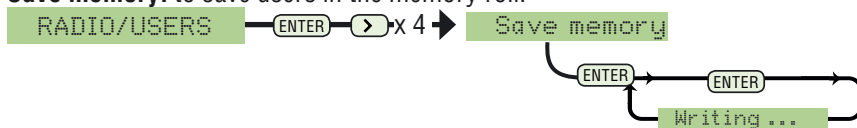

**Load memory:** to load the data saved in the memory roll.

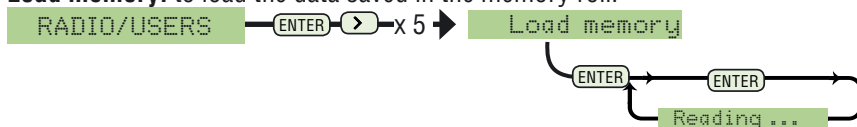

**Delete all:** to delete all saved users.

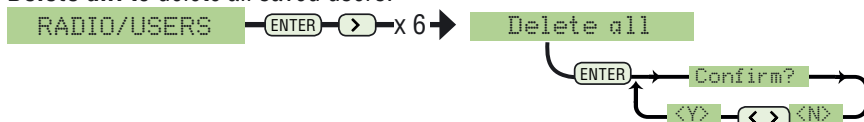

## Calibration

**Run calibration:** Adjusts the gate's run and the direction of Opening/Closing. (see pg. 14).



**Rib sensor:** adjusts the gate's sensitivity should obstacles be detected during movement.

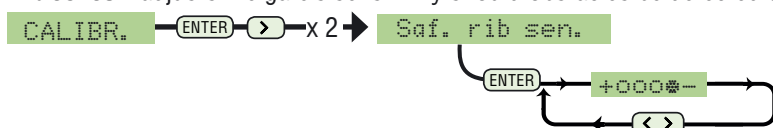

**Partial opening run:** adjusts the partial opening run.

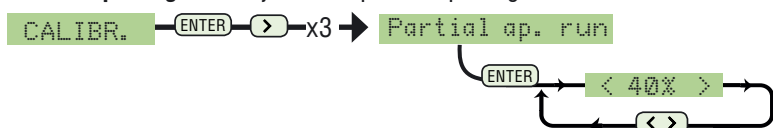

**Network ID:** Assigns a value from 1 to 16 for recognition via software

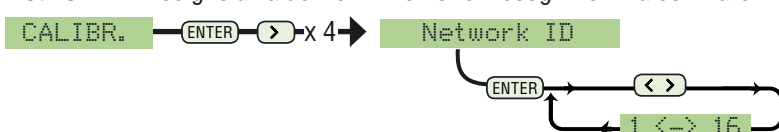

## INFO

**Version:** Displays the version of the software

**Number of operations:** Displays the number of the operations made.

**Initial message:** Sets the initial message on the display.



All the data and information contained herein is considered subject to change at any time and at our discretion.

## 6.5 Run adjustment

**[1]** From the adjustment menu, select Run adjustment and confirm by pressing ENTER

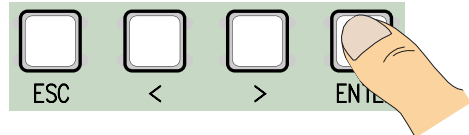
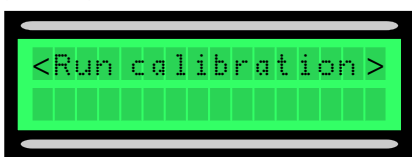

**[2]** Execute a complete run of opening using (<>), to reach the maximum opening point.

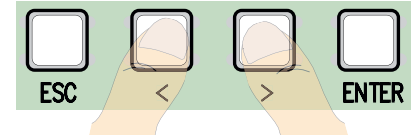

**[3]** Then confirm by pressing ENTER.

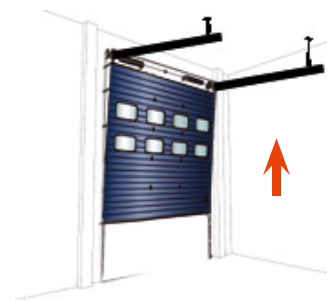

**[4]** Execute a complete run of closing using (>), to reach the maximum closing point.

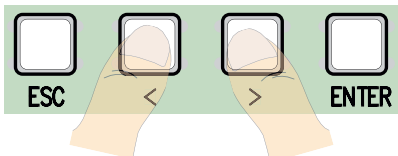

**[5]** Confirm by pressing ENTER.

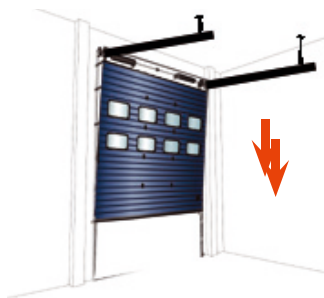

**[6]** Move the gate toward opening for at least 3 seconds

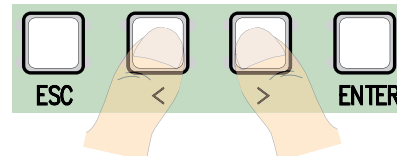

**[7]** Afterwards, confirm by pressing ENTER

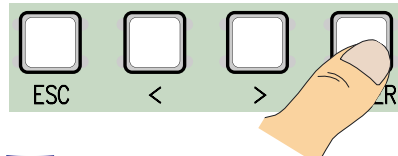

**[8]** Use the (<>) to bring the gate to the closing point.

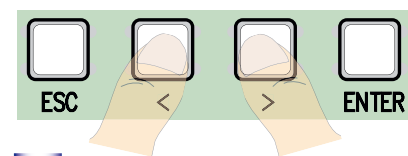
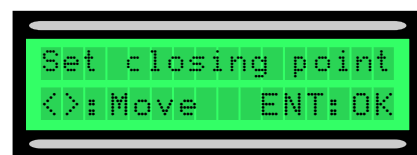

**[9]** Confirm by pressing ENTER.

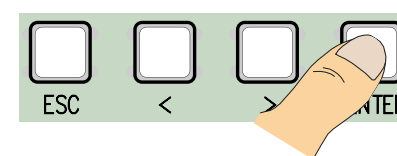
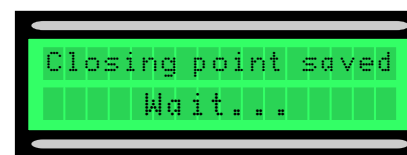

**[10]** Use the (<>) to bring the gate to the maximum opening point.

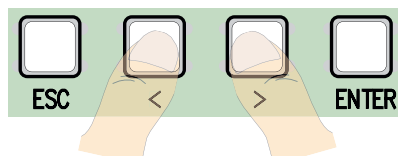
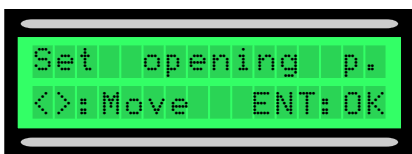

**[11]** Then confirm by pressing ENTER.

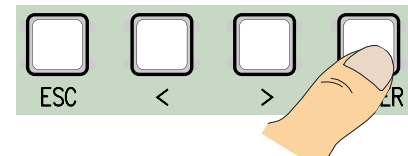
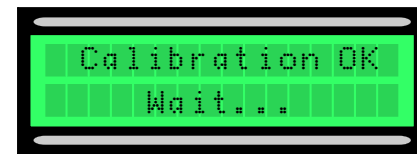

**[12]** If the calibration was not performed correctly or was unsuccessful, one of the following messages will appear:

- reprogram..... and then restart from point 1.

- reposition the encoder ... proceed with point 13

**[13]** Move the wheel toward + or - according to the instructions on the display

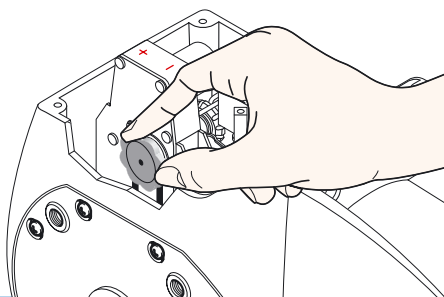

**[14]** Confirm by pressing Enter restart from point 1



All the data and information contained herein is considered subject to change at any time and at our discretion.

## 6.6 Decoder cards

To control the card by radio controls or passes, connect the AF radio card desired with the respective radio control and for the R700 card for TSP00/LT001 proximity sensors.

 N.B. if the appropriate decoding board is not included, it is not possible to enter users (the maximum no. of users that may be entered is 250)

 AF and R700 boards should be inserted with the power switched off.

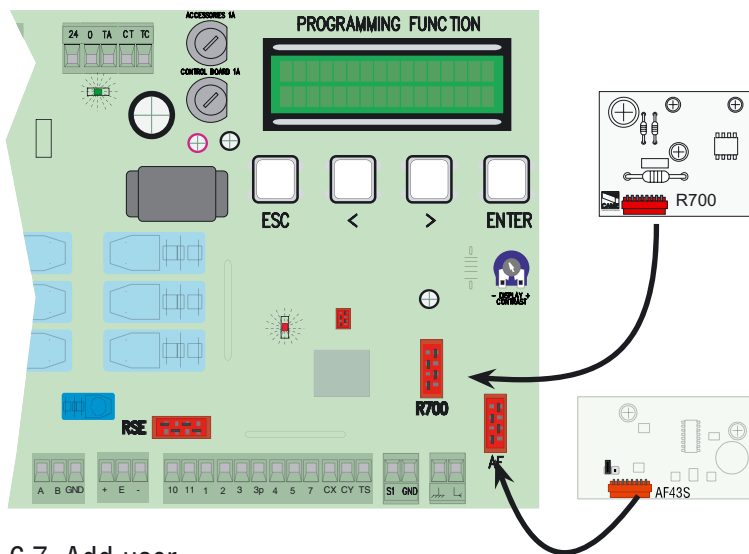

Frequency/MHz	Board	Trasmitter
FM 26.995	AF130	TFM
FM 30.900	AF150	TFM
AM 26.995	AF26	TOP
AM 30.900	AF30	TOP
AM 433.92	AF43S / AF43SM	TAM / TOP
AM 433.92	AF43SR	ATOMO
AM 40.685	AF40	TOUCH

## 6.7 Add user.

**[1]** From the Radio/Users, select New User confirm by pressing ENTER

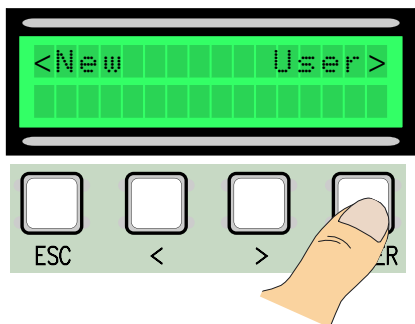

**[2]** Select either the user function and partial opening function to associate with the user, then confirm with ENTER...

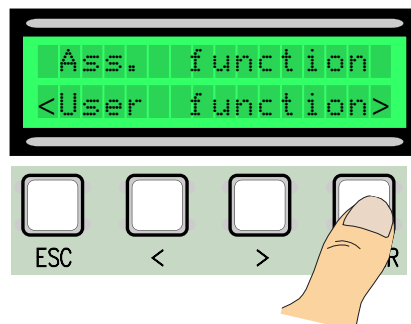

**[3]** ...a message will prompt entering the correct code with the radio control, swipe pass or transponder, depending on the type of sensors installed in the system in question.

As soon as the machine reads the code of the radio control or pass, the message "Memorized" will appear if the code is not present in the card, otherwise an error will be signalled.

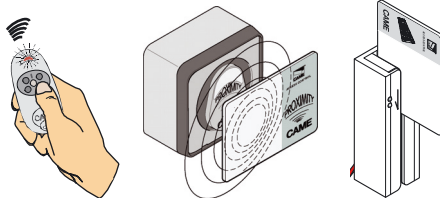

**[4]** In any case, the window will appear prompting if we want to enter a new code or number.

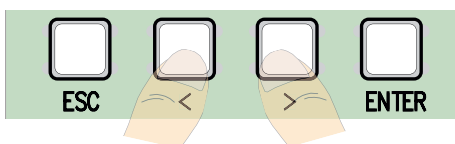
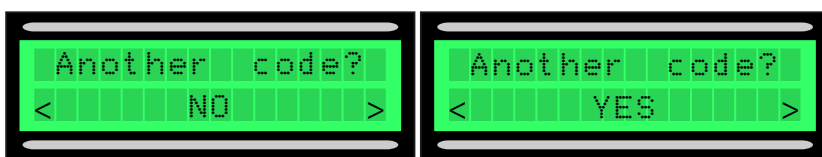

If we select NO, we will terminate the user entry procedure. If we select YES, the operations will resume from point 3.

All the data and information contained herein is considered subject to change at any time and at our discretion.

## 6.8 Change users (user function)

[1] Select Change user from the Radio/ User menu. Confirm by pressing ENTER

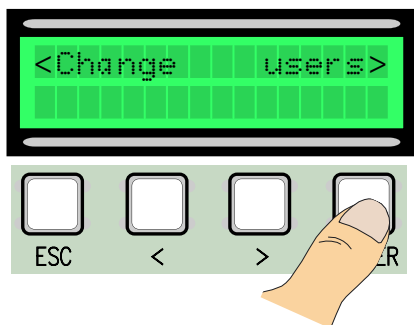

[2] Select the user whose associated function needs to be changed using the <> keys to move or press the transmitter key associated with it or swipe the card on the sensor, confirm by pressing ENTER.

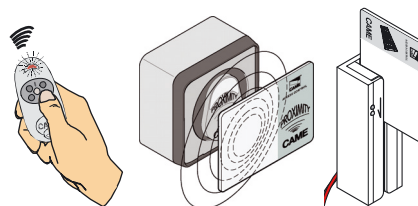
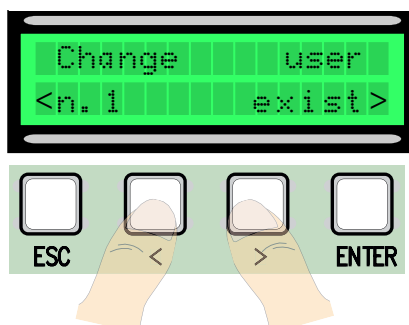

[3] Select the function to associate with the user, confirm by pressing ENTER. P.S. Confirming with ENTER, brings back the Change User window.

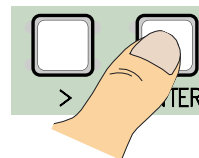
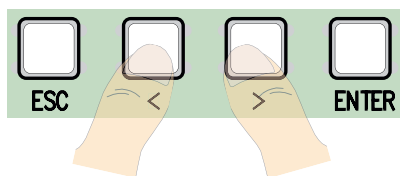
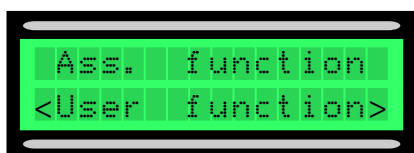

## 6.9 Change the initial message

[1] Select Initial message from the INFO menu, confirm by pressing ENTER

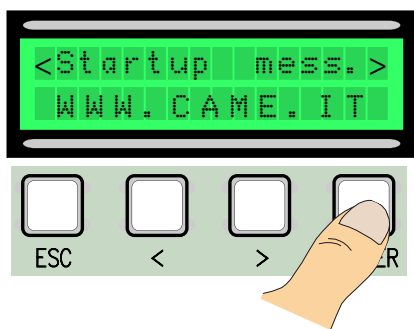

The ENTER key serves to :  
 - Move the cursor to the right  
 - If pressed for more than 3 seconds, it confirms



The ESC key serves to :  
 - Move the cursor to the left  
 - If pressed for more than 3 seconds, it exits

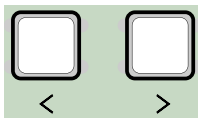

The < > keys serve to :  
 - select the letter desired and the space key

[2] Move inside the display as explained previously to obtain the desired message. The maximum limit of characters is 32 or 16 per row. Once the message is written, keep the ENTER key pressed for at least 3 seconds.





## 6.10 Error Messages

- “STOP contact open”: check the correct connection or the efficiency of the device connected.
- “Service Test!!!”: There is a malfunction with the connected safety devices.
- “Encoder not working”: check the correct connection or the efficiency of the device connected.
- “CX-CY contact open”: check the correct connection or the efficiency of the device connected.

## 7 Case Cover Assembly

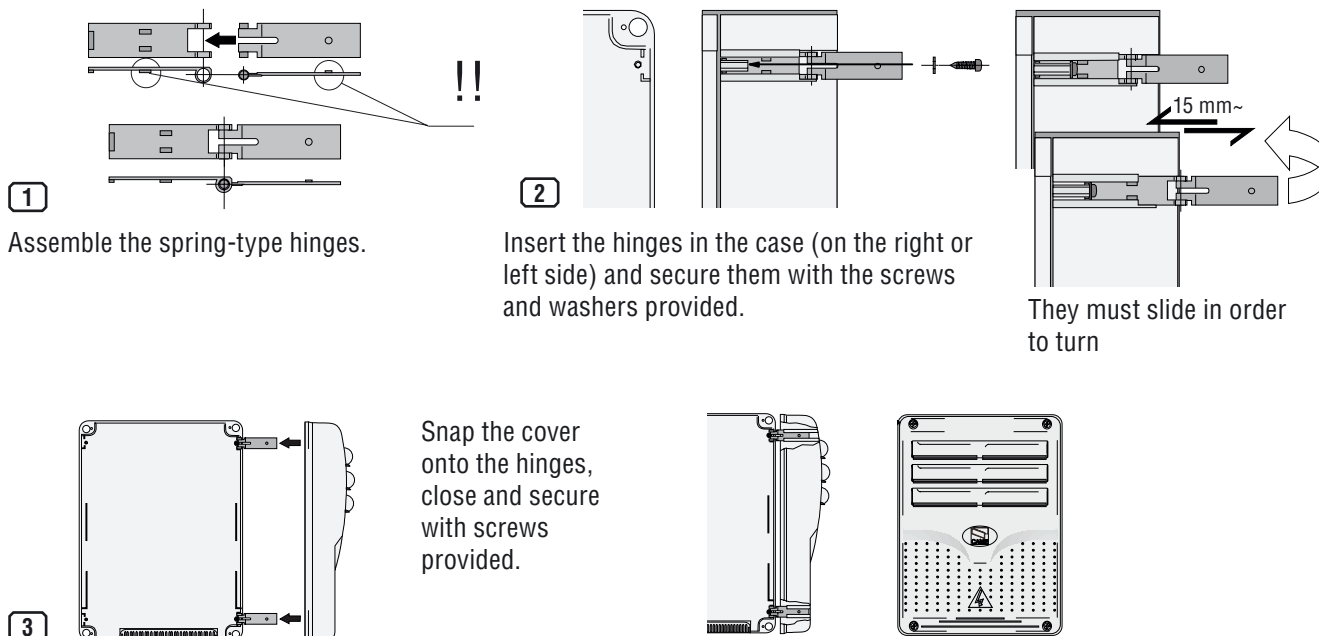

## 8 Disposal



This product, including packaging, is made of different materials that may be recycled. Please inquire on disposal or recycling systems for the product in compliance with local regulations in force.



Some electronic components could contain polluting substances, please dispose of properly.

## 9 Maker's statement



### MANUFACTURER'S DECLARATION

As per Enclosure II B of Machinery Directive 98/37/CE

Enclosed with the technical documentation (the original copy of the Declaration is available on request)

Date of the present declaration 07/12/2001

The representatives of

**CAME Cancelli Automatici S.p.A.**  
 via Martiri della Libertà, 15  
 31030 Dosson di Casier - Treviso - ITALY  
 (+39) 0422 4940 - fax (+39) 0422 4941  
 internet: www.came.it - e-mail: info@came.it

Hereby declare, under their own responsibility, that the product/s called ...

**ZT5 - ZT5C**

Also, they furthermore represent and warrant that the product/s that are the subject of the present Declaration are manufactured in the respect of the following main harmonized provisions:

- |                     |  |
|---------------------|--|
| EN 292 PART 1 AND 2 | MACHINERY SAFETY.                                      |
| EN 12453            | INDUSTRIAL, COMMERCIAL AND OTHER CLOSING MECHANISMS.   |
| EN 12445            | INDUSTRIAL, COMMERCIAL AND OTHER CLOSING MECHANISMS.   |
| EN 12978            | SAFETY DEVICES FOR POWER OPERATED DOORS AND GATES .... |
| EN 60335 - 1        | SAFETY IN APPARATUS FOR HOME USE.                      |
| EN 60204 - 1        | MACHINERY SAFETY.                                      |
| EN 61000 - 6 - 2    | ELECTROMAGNETIC COMPATIBILITY.                         |
| EN 61000 - 4 - 4    | ELECTROMAGNETIC COMPATIBILITY.                         |
| EN 61000 - 4 - 5    | ELECTROMAGNETIC COMPATIBILITY.                         |

**IMPORTANT CAUTION!**

It is forbidden to market/use product/s that are the subject of this declaration before completing and/or incorporating them in total compliance with the provisions of Machinery Directive 98/37/CE

Signatures of the Representatives

TECHNICAL MANAGER  
 Mr. Gianni Michielan

MANAGING DIRECTOR  
 Mr. Paolo Menuzzo

... comply with the Italian National Legal Provisions that transpose the following Community Directives (where specifically applicable):  
 MACHINERY DIRECTIVE 98/37/CE  
 LOW VOLTAGE DIRECTIVE 73/23/EEC - 93/68/EEC  
 ELECTROMAGNETIC COMPATIBILITY DIRECTIVE 89/336/EEC - 92/31/EEC  
 R&TTE DIRECTIVE 1999/5/CE

All the data and information contained herein is considered subject to change at any time and at our discretion.

**CAME UNITED KINGDOM LTD**  
UNIT 3, ORCHARD BUSINESS PARK  
TOWN STREET, SANDIACRE  
NOTTINGHAM - NG10 5BP - U.K.  
Tel 0044 115 9210430  
Fax 0044 115 9210431

